

**IMPORTANT:** Please read and save these instructions. Read through this owner's manual carefully before using product. Protect yourself and others by observing all safety information, warnings and cautions. Failure to comply with instructions could result in personal injury and/or damage to product or property. Please retain instructions for future reference.

# **PETROL CHIPPER SHREDDER**

---

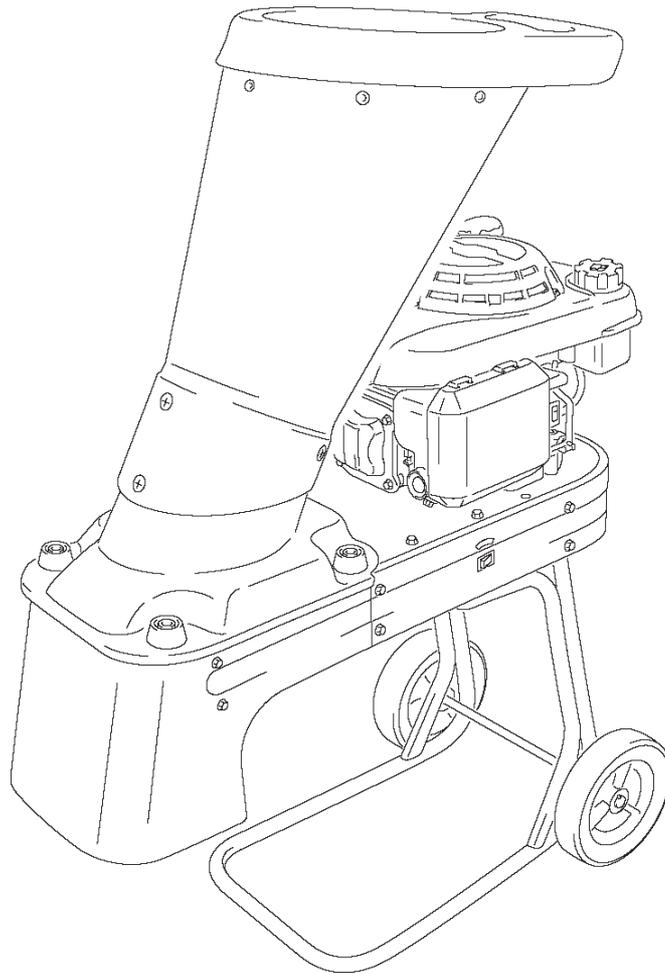

Due to continuing improvements, actual product may differ slightly from the product described herein.

# **OPERATING INSTRUCTIONS**

---



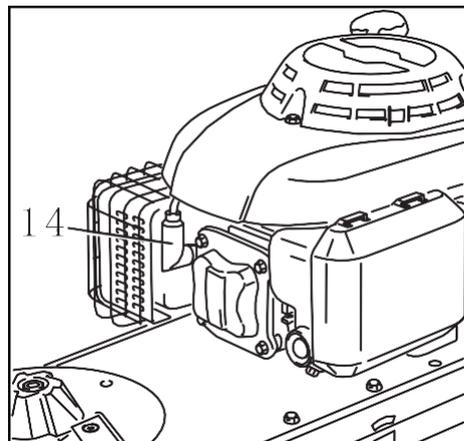
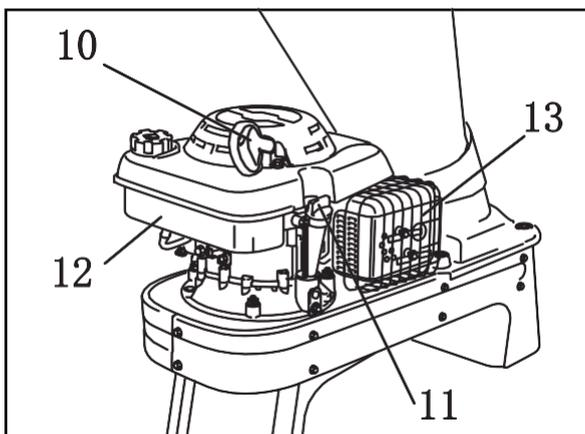
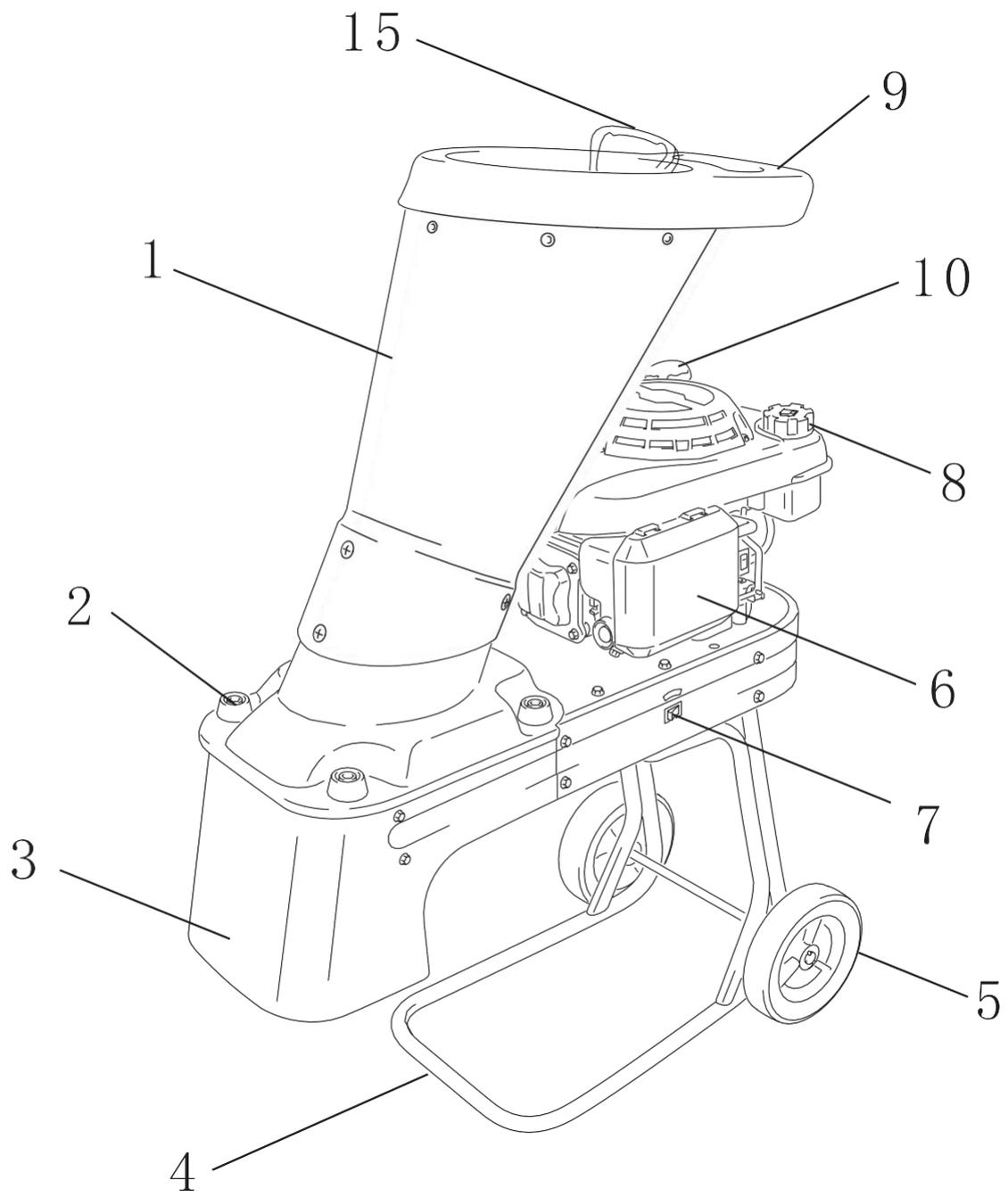

# GASOLINE SHREDDER

## 1 APPLICATION

This shredder is designed for composting/cutting of fibrous and woody garden waste. It is not designed for commercial use.



**WARNING! Please read and understand this operating manual before use and keep it for your future reference. Your power tool should only be passed on together with these instructions.**

## 2 DESCRIPTION

- |                      |                         |
|----------------------|-------------------------|
| 1. Hopper            | 9. Hopper handle        |
| 2. Fixing Bolt       | 10. Starter handle      |
| 3. Discharge chute   | 11. Oil filler cap      |
| 4. Leg               | 12. Fuel tank           |
| 5. Wheel             | 13. Muffler             |
| 6. Air cleaner cover | 14. Spark plug          |
| 7. On/Off Switch     | 15. Material Push stick |
| 8. Fuel filler cap   |                         |

## 3 PACKAGE CONTENT LIST

- / Remove all packing materials
- / Remove remaining packaging and transit supports (if existing)
- / Check the completeness of the packing content
- / Check the appliance, the power cord, the power plug and all accessories for transportation damages.
- / Keep the packaging materials as far as possible till the end of the warranty period. Dispose it into your local waste disposal system afterwards.



**WARNING Packing materials are no toys! Children must not play with plastic bags! Danger of suffocation!**

Gasoline shredder  
manual book  
Plunger



**When parts are missing or damaged, please contact your dealer.**

## 4 EXPLANATION OF SYMBOLS

In this manual and/or on the machine the following symbols are used:

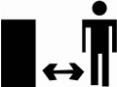
	Warning / Danger		Wear ear protection
	Read manual before usage		Wear eye protection
	Warning! Flying objects		Wear gloves
	Keep bystanders away		Wear safety boots to protect your feet
	Keep hands and feet out of openings while machine is running		Petrol is flammable. Allow engine to cool for at least 2 minutes before refuelling
	Danger – rotating blades		Petrol engines emit carbon monoxide. DO NOT run in enclosed area.
	Do not touch a hot silencer or cylinder. You may get burned. These parts get extremely hot from operation. When turned off they remain hot for a short time		

## 5 ADDITIONAL SAFETY RULES FOR SHREDDERS

- / Wear protective gloves, protective glasses and hearing protectors. Avoid loose clothing.
- / Always stand steadily and in balance. Do not stretch towards the machine.
- / During use, the machine should be level and on a firm surface.
- / Ensure that all screws and nuts are properly tightened before use.
- / Only use the machine in dry conditions and never use outdoors when it is raining.
- / Never use the machine with damaged safety devices or without protection.
- / Keep hands, other parts of our body and clothing away from the feeding hopper and the discharge chute.
- / Keep your face and the rest of your body away from the feeding hopper.
- / Do not leave the machine unsupervised, switch off the motor and disconnect the plug.
- / Hard objects such as stones, bottle, cans or pieces of metal must not be fed into the inlet chute. This can cause damage to the machine.
- / If the machine becomes blocked, stop the motor and disconnect the plug. Pull out any objects and check for damage.

- / If the fuse blows or if the overload protection is triggered, this is a sign that the machine is overloaded and/or that too many appliances are connected to the same extension cable. Check the cause and remedy. Do not install a more powerful fuse.
- / Do not tug on the extension cable. Do not hold the cable taut. This can cause damage in the plugs or in the cables insulation. Such damage is invisible but can be dangerous.
- / Always keep the extension cable away from the machine. Disconnect the plug from the electric socket and check the cable regularly for signs of damage or aging. Do not use the machine with a damaged extension cable.
- / If the cable is damaged, it must be replaced by an authorized service centre in order to avoid a hazard.
- / Never move the machine by pulling the cable. The machine must not be moved with the motor running.
- / The shredder must be assembled correctly before use.
- / Warning! This appliance must be earthed!
- / Warning! Use only three core extension cables with the earth wire connected.
- / Only use extension cables that are approved for outdoor use and check that they are in good condition before use.
- / Before inserting the plug in the mains socket, make sure that the socket ratings are correct and correspond to those indicated on the rating label on the shredder.
- / Always switch off the shredder before disconnecting any plug and socket connector or extension cables.
- / Keep children and pets away. All onlookers should be kept a safe distance away from the shredder when it is in use.
- / Do not allow children or any person who has not read this instruction leaflet or who is not familiar with the shredder to operate it.
- / The operator is responsible for third parties while working with the shredder.
- / Only use the shredder for its intended purposes.
- / Caution! There are rotating blades on this machine.
- / Caution! Blades do not stop immediately after switching off.
- / Always switch off the shredder, disconnect the plug and wait until the cutting disc stops before carrying out maintenance or cleaning work.
- / It is forbidden to move or modify any of the electrical and mechanical safety devices.
- / Use only in daylight or good artificial light.
- / Do not put your hands into the feed funnel or ejection slot.
- / If the shredder should start to vibrate abnormally, switch off the motor and check for the cause immediately. Vibration is generally a warning of trouble.
- / Ensure blades are secure before shredding. Do not operate the shredder if any of the blades are not properly mounted.
- / The shredder should be checked carefully before use. You should only work with a shredder that is in good condition. If you notice any defect on the machine that may cause danger to the operator, do not operate the shredder until defects are rectified.
- / Replace worn or damaged parts for safety. Use only original spare parts. Parts not produced by manufacturer may cause poor fit and possible injury.
- / Use the shredder only in places where it is protected from water and never use it outdoors in rainy weather.
- / Store in a dry secure place out of reach of children,
- / This appliance is not intended for use by persons (including children) with reduced physical, sensory or mental capabilities, or lack of experience and knowledge, unless they have been given supervision or instruction concerning use of the appliance by a person responsible for their safety.
- / Children should be supervised to ensure that they do not play with the appliance.

### **5.1 Preparation:**

- / Do not allow children to operate this equipment
- / Do not operate this equipment in the vicinity of bystanders
- / Wear ear protection and safety glasses at all times while operating
- / Avoid wearing clothing that is loose fitting or that has hanging cords and ties
- / Only operate the machine in open space (e.g. Not close to a wall or other fixed objects) and on a firm, level surface
- / Do not operate the machine on a paved or gravel surface, where ejected material could cause injury
- / Before starting the machine, check that all screws, nuts, bolts, and other fasteners are properly secured and that guards and screens are in place. Replace damaged and unreadable labels

### **5.2 Operation:**

- / Before starting the machine, look into the feeding chamber to make certain, that it is empty
- / Keep your face and body away from the feed intake opening
- / Do not allow hands or any other part of the body or clothing inside the feeding chamber, discharge chute, or near any moving part
- / Keep proper balance and footing at all times. Do not overreach. Never stand at a higher level than the base of the machine, when feeding material into it
- / Always stand clear of the discharge zone when operating this machine
- / When feeding material into the machine be extremely careful that pieces of metal, rocks, bottles, cans or other foreign objects are not included
- / If the cutting mechanism strikes any foreign objects or if the machine should start making any unusual noise or vibration, shut off the power source and allow the machine to stop, disconnect the spark plug wire from the spark plug ( electric unit disconnect from supply) and take the following steps:
  1. Inspect for damage
  2. Check for and tighten any loose parts
  3. Have any damaged parts replaced or repaired with parts having equivalent specifications
- / Do not allow processed material to build up in the discharge zone; this may prevent proper discharge and can result kickback of material through the feed intake opening
- / If the machine becomes clogged, shut off the power source and disconnect the spark plug wire from the spark plug (electric unit disconnect from supply) before clearing debris. Keep the power source clear of debris and other accumulations to prevent damage to the power source or possible fire. Remember that operating the starting mechanism on engine powered machines will still cause the cutting means to move
- / Keep all guards and deflectors in place and in good working condition
- / Do not tamper with the power source governor settings; the governor controls the safe maximum operating speed and protects the power source and all moving parts from damage caused by over speed. Seek authorized service if a problem exists.
- / Do not transport this machine while the power source is running
- / Shut off the power source and disconnect the spark plug lead (electric unit disconnect from supply) whenever you leave the work area
- / Do not tilt the machine while the power source is running

### **5.3 Maintenance and storage**

- / When the machine is stopped for servicing, inspection, or storage, or to change an accessory, shut off the power source, disconnect the spark plug wire from the spark plug (electric unit disconnect from supply), make sure that all moving parts have come to a complete stop and, where a key is fitted remove. Allow the machine to cool before making any inspections, adjustments, etc
- / Store the machine where fuel vapor will not reach an open flame or spark. For extended storage periods, run the unit dry of fuel. Allow the machine to cool before storing.
- / When servicing the cutting means be aware that, even though the power source will not start due to the interlock feature of the guard, the cutting means can still be moved by a manual starting mechanism.

### **5.4 Additional safety instructions for units with bagging attachments**

- / Shut-off the power unit before attaching or removing the bag.

## **6 SAFETY WARNINGS GASOLINE**



**WARNING: Use extra care in handling fuels. They are flammable and the vapours are explosive. The following points must be observed.**

- / Use only an approved container.
- / Never remove the fuel cap or add fuel with the power source running. Allow engine exhaust components to cool before refuelling.
- / Do not smoke.
- / Never refuel the machine indoors.
- / Never store the machine or fuel containers inside, where is an open flame, such as a water heater.
- / If fuel is spilled, do not attempt to start the power source, but move the machine away from the area of spillage before starting.
- / Always replace and securely tighten the fuel cap after refuelling.
- / If the tank is drained, this should be done outdoors.

## 7 ASSEMBLY INSTRUCTIONS

### 7.1 Hopper installation

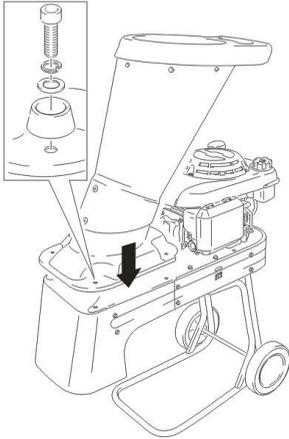

- / Carefully lift up the hopper
- / Place and align the hopper on top of the hopper seat.
- / Locate the screw to secure the hopper with the base unit.

### 7.2 Wheel installation

- / Lift the machine a little, and reeve the wheel with the wheel shaft.
- / Reeve a washer, and insert a pin to fix.
- / Repeat above processes to install another wheel

### 7.3 Move the shredder

- / Stand at the back of shredder
- / Grab the hopper handle, and step on the wheel axle.
- / Pull down the handle to slant backward the shredder.
- / Move the shredder.

## 8 BEFORE STARTING ENGINE

### 8.1 Oil

- / Use a high quality detergent oil classified "API service category SE or SF".
- / SAE 10W-30 is recommended for general use. Other viscosities shown in the chart may be used when the average temperature in your area is within the indicated range.
- / Do not use special additives.

#### 8.1.1 Oil capacity

The engine holds approximately 0.55 litres.

### 8.1.2 Check oil level



**Warning! Running engine with insufficient oil will cause serious engine damage.**

**Warning! When checking oil stop engine and place it on a level, surface.**

- / Remove dipstick and wipe clean with cloth.
- / Replace dipstick back without lock it in. Pull the dipstick out and check the oil level.
- / Oil level should be at upper limit on dipstick.
- / If the oil level is near or below the lower limit mark on the dipstick, add oil slowly and recheck until oil level reaches upper limit of dipstick. Do not overfill.
- / Replace and tighten dipstick.



**Warning! Using dirty oil or two-stroke engine oil will shorten engine useful life.**

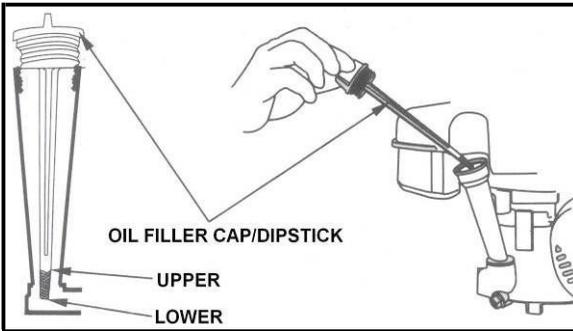

### 8.1.3 Fuel

- / This engine is certified to operate on unleaded petrol with a minimum of 85 octane. Fresh fuel prevents gum from forming in the fuel system.
- / Do NOT mix oil with petrol.
- / Keep dust, water and foreign matter away from fuel tank.
- / Do NOT use gasoline which contains Methanol.



**Warning! Gas is extremely flammable; it will explode if exposed to a source of ignition.**



**Warning! Turn engine OFF and let engine cool before removing gas tank cap. Always add fuel at well-ventilated place. Keep gasoline from sparks, open flames, heat and other ignition sources.**

**Warning! Don't overfill fuel. The fuel level should be always below the lowest position of the fuel tank neck.**



**Warning!** Check fuel lines, tank, cap and fittings frequently for cracks or leaks. Replace if necessary.



**Warning!** Prevent skin from frequent contact with gasoline.

**Warning!** Keep children and the frail at a safe distance during refueling.

#### 8.1.4 Adding Fuel

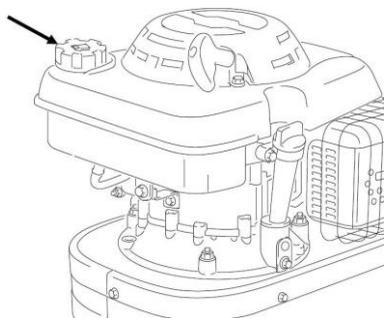

- / Remove fuel cap
- / Fill tank to the lowest position of the fuel tank neck. Do not overfill.
- / Wipe any gasoline that may have spilled.
- / Reinstall the fuel cap.

Fuel tank capacity: 1.2 liters

## 9 OPERATING INSTRUCTIONS

### 9.1 *Before starting engine*



**Warning!** Damage to your eyes, hands and ears could result from using this machine without proper protective gear. Always wear safety glasses, hearing protection, and leather gloves when operating this machine



**Warning!** Loose hair and clothing could get caught in machinery and cause serious personal injury. Keep loose clothing and long hair away from moving machinery.

Make sure to check the engine oil and fuel tank before starting the engine.

## 9.2 To start engine

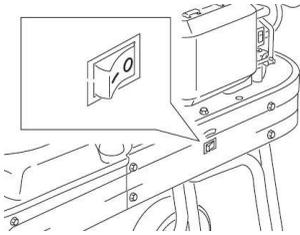

1. Move ON/OFF switch to "ON" position

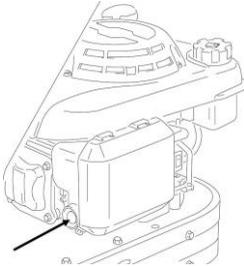

2. Press the primer pump 2-3 times. Do not press it exceed 5 times, otherwise, it will be hard to start.

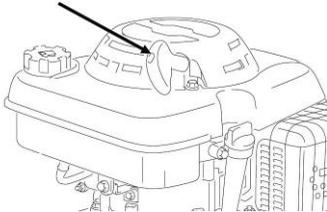

3. Pull the starter rope until the engine start up.

Note: If engine fails to start after repeated attempts, refer to troubleshooting section.

Note: Always pull starter rope straight out. Pulling starter at an angle will cause rope to rub against the eyelet. This friction will cause the rope to fray and wear more quickly. Always hold starter handle when rope retracts. Never allow rope to snap back from extended position. This could cause rope to snag or fray and also damage the starter assembly.

## 9.3 Warm engine start

- / Move On/OFF switch to "ON" position.
- / Pull the starter rope until the engine start up.

## 9.4 To stop engine

- / Move ignition switch to the "STOP" position.

**9.5 Top Hopper-front cut**



The large sloping front chute of the Top Hopper is designed to accept leaves and small garden clippings. Shredding and mulching is achieved by natural suction of the debris through the blade chamber.

Do not overfeed and do not feed wet, soggy material into the shredder as this may clog the blade chamber and the discharge chute.

**9.6 Top hopper-back chute**



The smaller back chute of the top hopper accepts medium to larger size garden clippings.

Shredding and mulching is achieved through the same action as the front chute. If a finer type mulch is required, re-feed the mulch through again until the desired result is obtained.

**9.7 Material Push stick**



User supplied push stick to push remaining material into hopper opening. **DO NOT USE HANDS.**

## 10 MAINTENANCE



**Warning!** Priors to any maintenance, to stop engine and switch it off first.

**Warning!** Disconnect spark plug wire from the spark plug to prevent unintentional engine starting.

**Warning!** Unintentional sparking can result in fire.



**Warning!** Unintentional start-up can result in entanglement, traumatic amputation, or laceration.



**Caution!** Use only genuine replacement engine parts. None compliant parts may damage the engine, and may result in injury. In addition, use of other parts may void your warranty rights.

Regular maintenance will improve the performance and extend the life of the engine. Please follow the instructions and schedules indicated below:

	Before each use	5 Hours or first month	25 hours or every 3 months	50 hours or every 6 months	100 Hours or every year
Check oil level	!				
Change oil		!		! # \$ %	
Check air cleaner	!				
Clean Air cleaner			! # & %		
Replace Air cleaner					! !
Check-clean spark plug				!	
Replace spark plug					!
Check flywheel brake pad				!	
Check-adjust idle speed					! # * %
Check-adjust valve clearance					! # * %
Clean combustion chamber	After every 100 hours (3)				
Check fuel line	Every 2 years (replace if necessary) (3)				

**!** Replace the paper element type only

(1) Change engine oil every 25 hours when used under heavy load or in high ambient temperatures.

(2) Clean more often under dusty conditions or when airborne debris is present. Replace air cleaner parts, if very dirty.

(3) These items should be serviced by your servicing dealer unless you have the proper tools and are mechanically proficient. Refer to manual for service procedures.

## 10.1 Blade Maintenance



**Warning!** Before removing Top Hopper knob, ensure the machine is switched off, and the machine is completely stopped.



**Warning!** If ejection chute becomes clogged or cutting blades become jammed under no circumstances should you place your hands in ejection chute to try to clear obstruction, as this will lead to serious injury.

- / Switch the machine off, and make sure the machine is completely stopped.
- / Loose five screws as shown on carefully lift up the hopper.
- / Dismantles bit anchor screw 2pcs with the suitable tool.
- / Sharpen or replace the blades, then tighten the screws.
- / Closes the hopper, and then tighten the screws.

## 10.2 Change oil

- / Let engine runs out of fuel, and wait until engine stopped and cooled slightly.
- / Disconnect spark plug wire and keep away from spark plug.
- / When engine is still warm, remove oil drain plug. Drain oil into a proper container.
- / Clean the oil drain plug before restoring it back.
- / Place engine level. Remove dipstick. Add new recommended oil about 0.3L slowly to upper limit on dipstick, don't overfill.
- / Replace dipstick.



**Warning!** Prevent skin contact with used engine oil. Wash your skin with soap and water after oil change.



**Caution:** Used oil is a hazardous waste product. It is suggested to bring used oil to your local recycling center with properly sealed container. Do not discard with household waste.

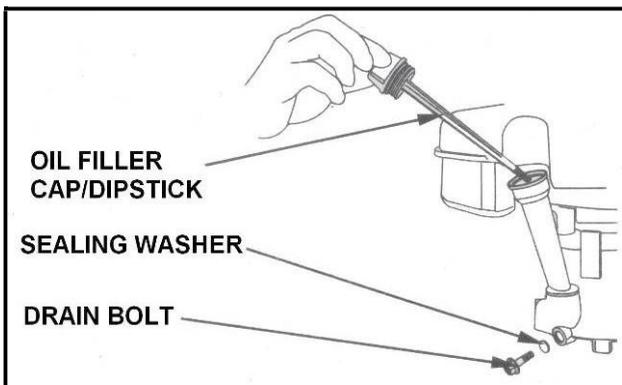

### 10.3 Air cleaner maintenance

A dirty air filter will increase air intake restriction. Periodical maintenance for air filter will help to improve engine performance and reduce emissions.



**Warning! Never clean air filter with gasoline or an easily ignited solvent as it may cause explosion.**

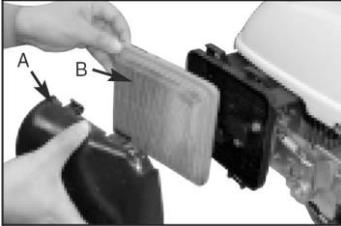

- / Remove the air cleaner cover (A), and carefully remove the filter element (B).
- / Clean all parts
- / Blow off dirt from filter element with pressure air.
- / Reinstall the filter element and air cleaner cover.

### 10.4 Spark Plug

- / Recommended spark plug: F7RTC.
- / Stop the engine and allow it to cool



**Warning! Do not use an incorrectly rated plug. It is essential to keep the spark plug in good condition – clean and properly adjusted.**



**Warning! To keep engine at top performance spark plug gap should be within specified and carbon built up free.**

- / Removing spark plug with a spark plug wrench.
- / Inspect the spark plug visually. If spark plug is worn, dirty or has cracks, replace with the recommended type and heat range.
- / The correct air gap is 0.70 to 0.80 mm
- / Tighten the spark plug
- / After spark plug is tight; torque to 25-30N m.



**Warning! An incorrectly tightened spark plug may result in poor engine performance and permanent engine damage.**

### 10.5 Combustion deposits

We recommend that you should remove combustion deposits from the cylinder, cylinder head, top of piston, and around valves after 100-300 hours usage.

### 10.6 Muffler



**Warning! If engine just running down, do not touch muffler. Allow it to cool before operation.**

### 10.7 *Transporting and storage*

When storing engine for more than 30 days:

- / Store in a dry and clean area
- / Run engine until fuel tank is empty and engine stops or add gasoline preservative and running engine after adding for several minutes to circulate preservative.



**Warning! Gasoline is flammable. Fuel or fuel vapors may explode. Keep sparks and open flames from the working area.**

- / Change engine lubrication oil.
- / Clean the exterior surfaces of the engine.
- / Remove spark plug, pour one teaspoon of fresh engine oil into cylinder. Re-install spark plug without the spark plug wire attached. Pull starter rope slowly several times to distribute the oil in the engine.
- / Slowly pull start handle until the resistance is reached, then stop pulling. At that point, valves are closed, that will prevent dust and rust from entering cylinder.
- / Cover engine well to prevent dust.



**Warning! When you service the engine, inspect the blade, or clean the underside of the housing: make sure to tip the engine with the spark plug up. Transporting or tipping the engine with the spark plug down will cause:**

**Engine smoking**



**Hard starting**



**Spark plug fouling**

**Oil or petrol saturation of the air filter.**

## 11 TROUBLESHOOTING

Problem	Probable cause	Corrective action
Engine will not start	Engine switch OFF	Turn the engine switch to ON
	Spark plug wire is not connected to the spark plug, or the spark plug is bad.	Connect the spark plug wire or replace the spark plug.
	No gas, or gas is old and stale.	If empty, fill the tank. If full, drain the gas, then fill the tank with fresh gas.
	Air filter is dirty.	Clean out the air filter.
	Engine oil is low.	Add oil to the engine.
Engine does not run smoothly	Blocked fuel line.	Clean out the fuel line.
	Air filter is dirty.	Clean the air filter
Engine overheats	Stale fuel, water or dirt in fuel, blocked fuel line.	Drain the fuel tank, clean out the fuel line, and fill the tank with fresh gas.
	Chips and sawdust around the motor.	Clean off the motor.
Machine vibrates or makes unusual noises	Dirty air filter	Clean out the air filter.
	Loose or damaged parts.	Check the blades, hammers, impeller, and all connections. Tighten, repair, or replace any loose or damaged parts.
Shredder no longer chips or shreds well.	Impeller or blades have woody residue or chunks stuck to them.	Clean the impeller and blades.
	Dull or damaged blades and hammers	Sharpen or replace blades and check the hammers for damage.
Chips do not come out of the discharge chute or come out slowly.	Loose, worn, or damaged V-belt.	Replace or tighten V-belt.
	Discharge chute or hopper is clogged.	Turn OFF the motor, disconnect the spark plug, then clean out the machine.

## 12 TECHNICAL DATA

Engine type	4-stroke, overhead valve single cylinder, vertical shaft
Engine displacement	159cm <sup>3</sup>
Power	3.0 kW
Cooling system	Forced air
Max. cutting diameter	50mm
Ignition system	Transistorized Magneto Ignition
Max. cutting speed	2570min <sup>-1</sup>
Max. engine speed	3600min <sup>-1</sup>
Blade type	H-type
Starting system	Recoil start
Fuel volume	1.2L
Oil volume	0.55l
Fuel type	Unleaded gasoline

## 13 ENVIRONMENT

Should your appliance need replacement after extended use, do not discard it with the household rubbish but dispose of it in an environmentally safe way.

Please dispose of used motor oil in a manner that is compatible with the environment. We suggest you take it in a sealed container to your local service station for reclamation. Do not throw it in the trash or pour it on the ground.